

**PORTABLE PRESURIZED DOUBLE EYE WASH UNIT****PRODUCT FEATURES**

The double eye wash unit consists of:

- Eyewash body with soft rubber handlers.
- Aerated water flow activated by retention leverage.
- 1,5 m flexible hose.
- Stainless steel tank. Capacity: 18 liters drinking water, refillable pressurized at 6 bar.
- Pressure indicator and overload valve.

**TECHNICAL FEATURES**

- Capacity: 18 liters.
- Work pressure: 6 bar.
- Maximum opening valve: 7/9 bar
- Water flow: 6l / min.
- Water tank dimensions: 630 height, 220 Ø (mm).

**SUGGESTED USE**

In case of accidental chemical, acid or corrosive contamination, it guarantees an immediate and safe cleaning.

**MANIPULATION**

The unit is filled with 15 liters of potable water and pressurized to 6 bar of air taken from a compressed air compressor.

In case of use press the lever of the shower to drain the flow of water under pressure.

**MAINTENANCE**

- Store in a cool, dry place away from heat sources and protected from light.
- Periodically check the pressure at the pressure manometer.
- In case the pressure detected by the pressure indicator is below 4 Atm, restore with the help of a source of compressed air.
- Adjustable airflow through integrated device, built according to EN 15154-1-2.

**DIMENSIONAL DRAWING**

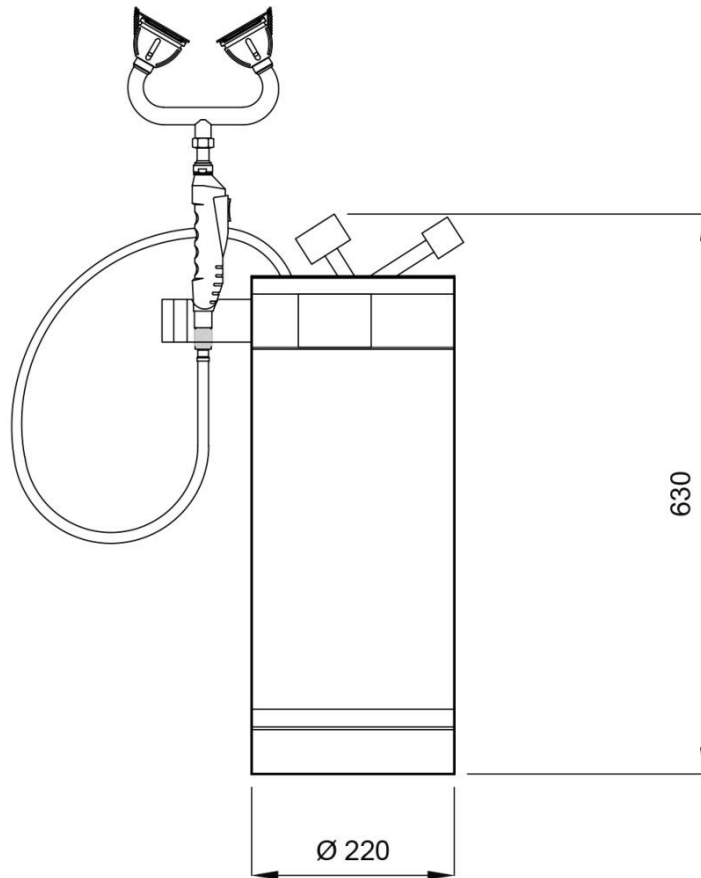

DIMENSIONS IN mm.